



CLIP top BLUMOTION 105°

for standard applications with integrated soft-close mechanism in all living areas

Technical data sheet

www.blum.com

 **blum**[®]



- CLIP top BLUMOTION with integrated BLUMOTION soft-close mechanism
- CLIP top with or without closing mechanism (spring)
- 105° opening angle
- 3-dimensional front adjustment
- Convenient spiral-screw adjustment
- Tool-free front to cabinet assembly and removal

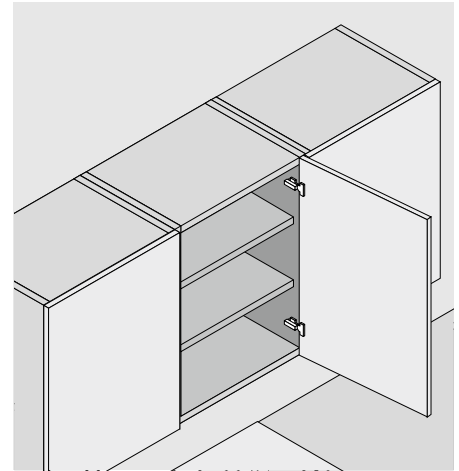



Ordering information

Boss <input type="checkbox"/> Screw-on			Overlay application	Half overlay application	Inset application
Hinge	Spring	Colour			
CLIP top BLUMOTION	●	NI	75B2550	75B2650	75B2750
CLIP top	●	NI	75T2550	75T2650	75T2750
	○	NI	74T2550.TL	74T2650.TL	74T2750.TL
Boss <input type="checkbox"/> Knock-in			Overlay application	Half overlay application	Inset application
Hinge	Spring	Colour			
CLIP top BLUMOTION	●	NI	75B2580	75B2680	75B2780
CLIP top	●	NI	75T2580		
Boss <input checked="" type="checkbox"/> EXPANDO			Overlay application	Half overlay application	Inset application
Hinge	Spring	Colour			
CLIP top BLUMOTION	●	NI	75B258E	75B268E	75B278E

Hinge arm cover cap			Overlay application	Half overlay application	Inset application
Print/stamp	Logo	Colour			
Plain	-	NI	70.1503	70.1663	70.1663
Stamped	Blum	NI	70.1503.BP	70.1663.BP	70.1663.BP



- Hinge with spring
- Unsprung hinge
- NI Nickel plated

Ordering information

		Hinge boss cover cap
---	---	-----------------------------

Colour



NI	70T3504
----	---------

		Opening angle stop
---	---	---------------------------

Opening angle

85°	R7037	94M2553
-----	-------	---------



Colour

		Hinge boss spacer
---	---	--------------------------

Boss

Screw-on

1.5 mm	70T3507.21
--------	------------

		Chipboard screw
---	---	------------------------

Ø (mm)
Length (mm)

3.5	15	609.1500
-----	----	----------

3.5	17	609.1700
-----	----	----------

		TIP-ON for doors	
---	--	-------------------------	--

Version
TIP-ON spring
Spring

Short version	■	○	956.1004
---------------	---	---	----------

Long version	■	○	956A1004
--------------	---	---	----------

Long version	■	●	956A1006
--------------	---	---	----------

Long version	■ ■	●	956A1006F
--------------	-----	---	-----------

● Hinge with spring

○ Unsprung hinge

■ Standard spring

■ ■ Strong spring

NI Nickel plated

R7037 RAL 7037 dust grey

Planning

Hinge dimensions and gap calculation based on factory setting (mounting plate spacing = 0 mm)

Front protrusion at full opening angle

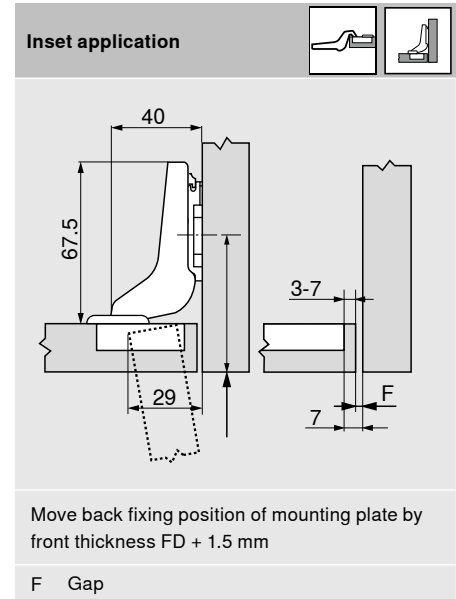
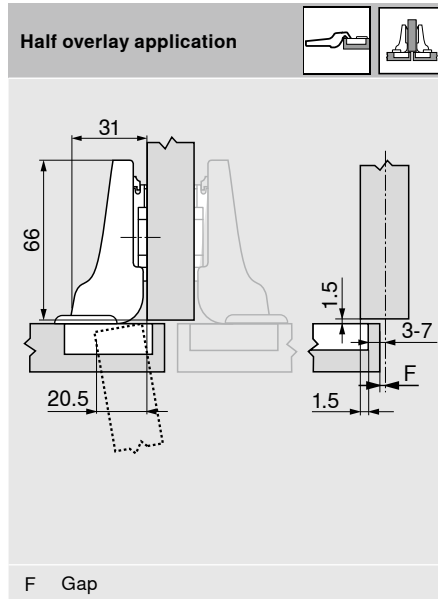
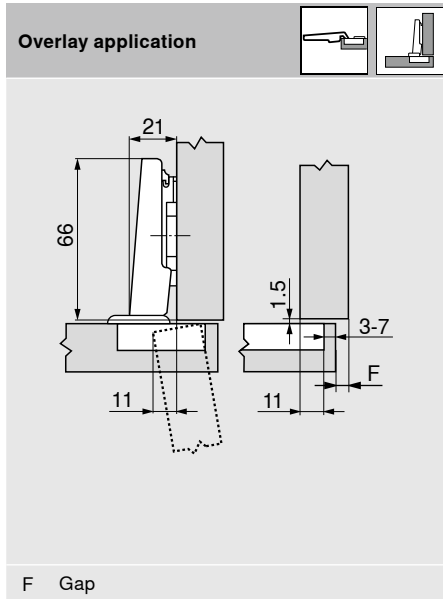

Drilling distance TB

MD	Front overlay FA (mm)																													
	5	6	7	8	9	10	11	12	13	14	15	16	17	18	5	6	7	8	9	10	11	12	13	14	15	16	17	18		
0																														
3																														
6																														
9																														

MD Mounting plate spacing (mm)

Minimum gap F for fronts with a front radius (R = 1 mm) based on the factory setting

Drilling distance TB (mm)	Front thickness FD (mm)							
	16	18	19	20	21	22	24	
3	0.5	0.8	1.0	1.2	1.5	1.8	2.7	
4	0.5	0.8	1.0	1.2	1.4	1.7	2.5	
5	0.5	0.8	0.9	1.2	1.4	1.7	2.4	
6	0.5	0.8	0.9	1.2	1.3	1.6	2.3	
7	0.5	0.8	0.9	1.1	1.3	1.6	2.2	
Additional for +2 mm side adjustment								
	+0.3	+0.3	+0.3	+0.4	+0.4	+0.4	+0.4	

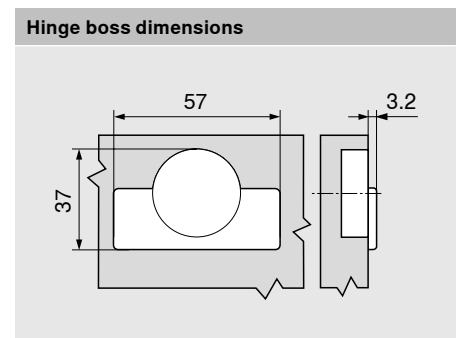
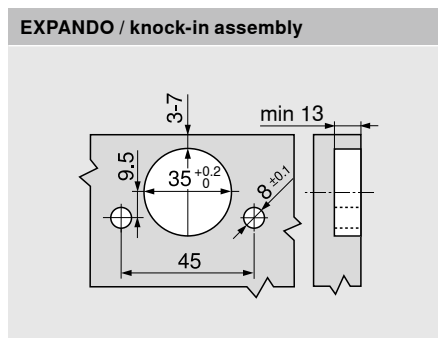
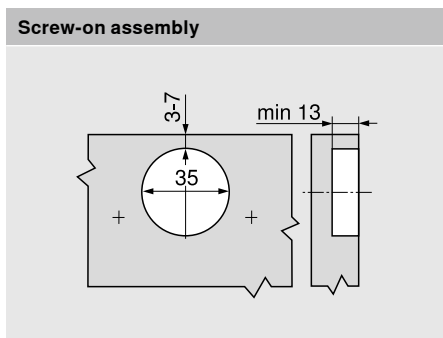
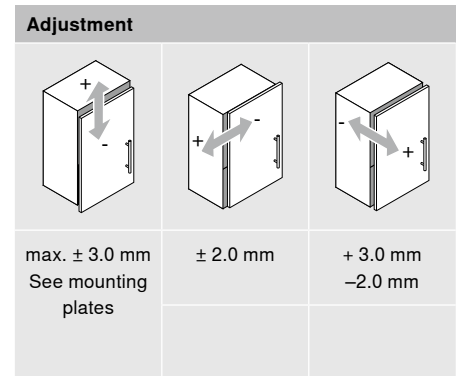

Julius Blum GmbH
6973 Höchst, Austria
Tel.: +43 5578 705-0
Fax: +43 5578 705-44
E-mail: info@blum.com
www.blum.com

Our sites in Austria, Poland and China are certified to the international standards mentioned below.
Our site in the USA is certified to ISO 9001.
Our site in Brazil is certified to ISO 9001, ISO 14001 and ISO 45001.



ISO 9001
Certified Quality
System



ISO 14001
Certified Environmental
System



ISO 50001
Certified Energy
System

 **blum**®



Look for our
FSC™-certified
products

All content is copyrighted by Blum.
Subject to technical modifications and changes to the range without notice.
TD-151/1 EN-AL/04.24